

INSTALLATION INSTRUCTIONS
AND RECOMMENDATIONS FOR USE AND MAINTENANCE

INDUCTION HOB

IR 321.1

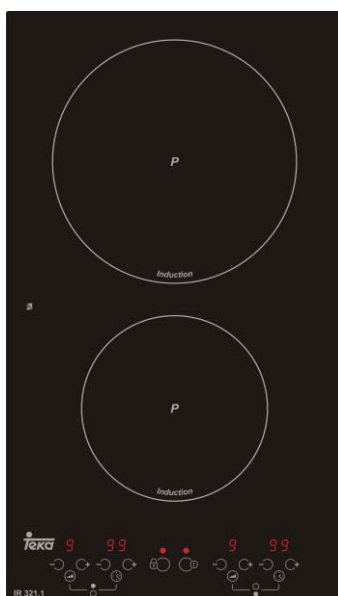

TeKa

Disposing of the device



When disposing of the device, do not bring it to regular municipal waste containers. Instead, bring it to electrical and electronic waste recycling and reuse center. A relevant label has been put on the device, its instructions manual, or the package.

The device has been manufactured of recyclable material. by bringing old device to recycling collection center, you show that you care about nature.

Ask your local environmental care authority for information on location of such facilities.

CONTENTS

WARNING.....	1-2
INSTALLATION.....	3
1.CUTTING THE CUPBOARD.....	3
2.PLACE OF INSTALLATION.....	4
3.PREPARING THE HOTPLATE.....	5
4.ELECTRICAL CONNECTION.....	5
WHAT'S SPECIAL ABOUT INDUCTION COOKING ?.....	6
1.POWER AND SAVINGS.....	6
2.SAFETY.....	6
3.CLEANING.....	7
FUNCTIONING.....	8
1.DESCRPTION OF THE HOB.....	8
2.USING THE TOUCH CONTROL.....	8
3.TIMER FUNCTION	9
4.PAN	10
WHAT SHOULD I DO IF.....	11
TECHNICAL DETAILS	12

WARNING

- In case of failure, only the Authorised Technical Service may repair this hob. Otherwise the guarantee will be null and void.
- The technical and identification data for the hob figure on the reference plate fixed to the appliance.
- This reference plate must be consulted before making the electrical connections.
- The electrical connections must be made by a specialist aware to the legal and regulatory, requirements in each country.
- Fill in table on the front cover with the data from the appliance reference plate.
- This appliances is not intended for use by persons (including children) with reduced physical. Sensory or mental capabilities, or lack of experience and knowledge, unless they have been given supervision or instruction concerning use of the appliance by a person responsible for their safety.
- Children should be supervised to ensure that they do not play with the appliance.

WARNING: if the surface is cracked, switch off the appliance to avoid the possibility of electric shock.

- Metallic objects such as knives, forks, spoons and lids should not be place on the hob surface since they can get hot.
- The appliance is not intended to be operated by means of an external timer or separate remote-control sysetm.

WARNING:The appliance and its accessible parts become hot during use. Care should be taken to avoid touching heating elements.

Children less than 8 years of age shall be kept away unless continuously supervised.

--The appliance can be used by children aged from 8 years and above and persons with reduced physical, sensory or mental capabilities or lack of experience and knowledge if they have been given supervision or instruction concerning use of the appliance in a safe way and understand the hazards involved.

--Children shall not play with the appliance.

Cleaning and user maintenance shall not be made by children without supervision.

--The instruction for ovens shall include the substance of the following:

WARNING: Accessible parts may become hot during use. Young children should be kept away.

INSTALLATION

1 CUTTING THE CUPBOARD

FITTING DIMENSIONS
induction Hobs

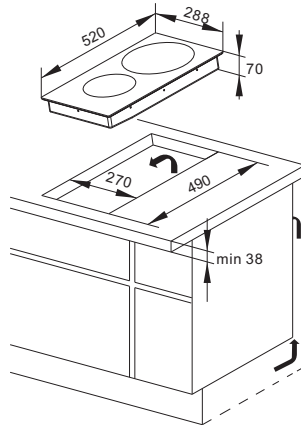

IMPORTANT

There must be a minimum distance of 100 mm between the hole and the wall or adjoining cupboard. If the hob is more than 30 mm thick, or if it is placed on a false top, the ventilation cover must be fitted as shown in the figure below.

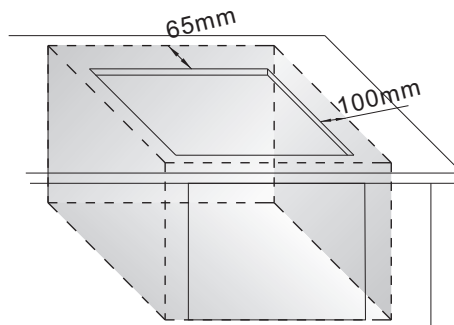

2 PLACE OF INSTALLATION

ABOVE A DRAWER

The electronic circuits of the induction hob must be cooled by a current of fresh air as shown in the diagram, and the points below must be carefully complied with. The greater the distance between the hob and the cupboard underneath it, the better the hob will function.

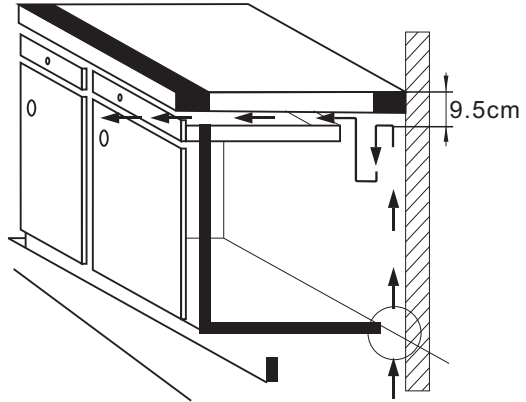

IMPORTANT

Your induction hob needs an air inlet at the rear and an air outlet at the front.

ABOVE A CUPBOARD WITH DOOR

When the air outlet is underneath the hob:

- a** Ideally, an air outlet grille should be placed between the hotplate and the cupboard door. It will be easy to install if the cross bar is small.

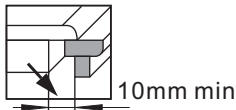

- b** If the cross bar is rectangular or the hotplate is closed off, make a bevelled cut to free the air outlet.

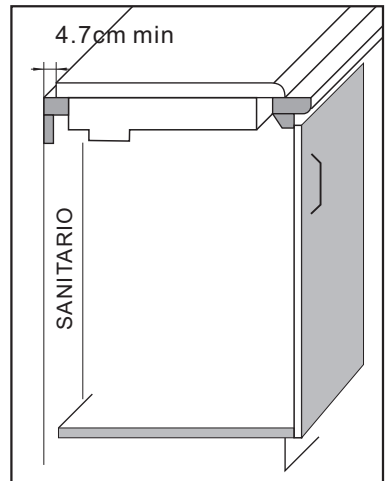
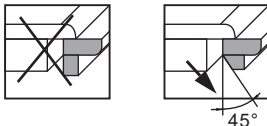

ABOVE A OVEN

The hotplate may be flush-mounted above an oven of the same brand.

This oven has an upper ventilation system and can therefore be installed in a high position.

To do this, remove the front cross bar of the cupboard to leave a minimum space of 5 mm free

IMPORTANT

Your induction hob must NOT be installed above a dishwasher, washing machine, refrigerator or freezer

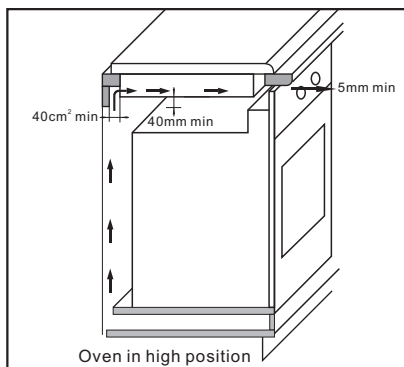

3 PREPARING THE HOTPLATE

Remove the adhesive paper and stick the seal provided with the appliance all around the hob.

4 ELECTRICAL CONNECTION

The vitro-ceramic hob is supplied with a power cable.

If the cable is damaged in any way it must be replaced by the manufacturer or after-sale service or by authorised technical staff, to avoid hazard.

If the mains supply where the hob is to be installed is different from 220...240V~, make the connection as shown in the enclosed diagrams. (The cable must be able to withstand temperatures of 90°)

It must be connected to the mains at a socket complying with EEC publication 7 or a single-pole cut-off device with a contact opening distance of at least 3 mm.

Technology date

HOB	Voltage	Total power	Nominal power per phase	Protection
IBB-30GT4FG	220...240V	3.0 KW	15.6A	20A

- 220-240V monophasé
hok-up~ -

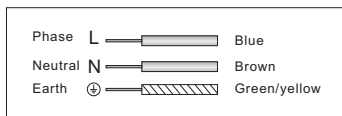

WHAT'S SPECIAL ABOUT INDUCTION COOKING

1 POWER AND SAVINGS

Induction hobs heat up food much more quickly than other systems do. As the heat is produced in the pan itself, much less energy is lost and performance is much better. Induction cooking uses up only half as much energy as other systems.

This lower consumption makes induction cooking the cheapest of all the electric cooking systems. It is almost as economical to use as a gas hob.

2 SAFETY

The risk of burns from the hot glass is minimal. As the heat is produced in the pan itself, the glass hardly heats up at all.

The induction rings have a pan detection system, i.e. the ring will not work unless there is a suitable pan on it.

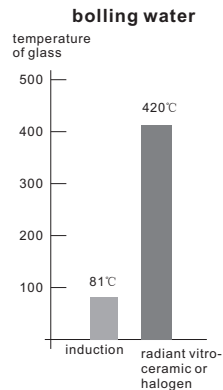
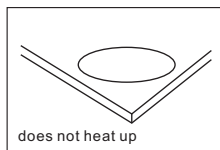
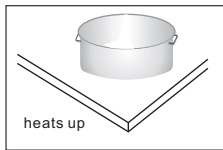

IMPORANT

TO THE ATTENTION OF CARDIAC PACEMAKER AND ACTIVE IMPLANT USERS: The hotplate complies with the current electromagnetic interference regulations. This induction hob fully complies with all legal requirements (EEC directives 89/336). It is designed not to interfere with the functioning of other electrical appliances, providing they comply with the same regulation.

THIS INDUCTION HOB GENERATES MAGNETIC FIELDS IN ITS IMMEDIATE SURROUNDINGS.

Your pacemaker must be designed in compliance with the corresponding regulations in order for no interference to be caused between it and the hotplate. Consult the pacemaker manufacturer or your doctor to determine whether it complies with the regulations in force or whether any incompatibilities exist.

3 CLEANING

Spills and splashes will not harden and stick to the glass, as it hardly heats up. Both Vitro-ceramic and induction rings should however be cleaned of any spills or splashes as quickly as possible.

Slight stains can be removed with kitchen paper or cloth.

More resistant stains will need specific product for vitro-ceramic glass. Follow each product's instructions.

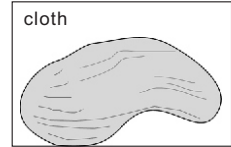
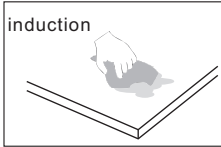

IMPORTANT

Do not use abrasive products or cleaning powders as these could scratch the hob.

Do not use a steam cleaner.

If any cracks should appear on the surface of the glass, unplug the appliance immediately. Do not use any part of the hob until a new vitro-ceramic glass has been installed.

FUNCTIONING

DESCRIPTION OF HOB

Ring indicators: These show the location of each ring on the hob .



Power displays: These show the power setting each ring is working on.



Residual heat indicator: when cooking over, an **H** lights and **0** light will up on alternate. the power display to indicate that a particular ring is very hot and should not be touched. It may remain till the cooktop is cool down.



+ and - sensors : These are for selecting the power setting of the rings, from 0 to 9 or setting the timer for cooking.



Booster sensor: To touch the ring indicator two seconds then the ring will be turned directly to the maximum setting when setting the power and waiting for cooking or on the cooking time. when the Booster function is running if you touch the power sensor which is running booster function it will return the power that before run the booster.

On/off sensor: Allows the hob to be switched on and off directly without using any other sensor.

Safety sensor and display: Allows the other sensors to be blocked to prevent



children playing with them, and their functioning to be viewed.

When the sensor block is activated, none of the other buttons can be activated. This will be indicated on the whole of the touch control.

Timer sensors: For setting a cooking time of between 0 and 99 minutes on the



selected ring. You can touch the timer sensor first, then use the increase and lessen to set your cooking time. After your cooking time is setting over, then choose your ring for cooking.

Timer displays: For viewing the cooking time on the ring selected.

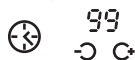

USING THE TOUCH CONTROL

SWITCHING ON A RING

- Place your fingertip on the on/off sensor. Remember there is a safety sensor to prevent children from playing with the controls, which is deactivated by leaving your fingertip on the control for three seconds. If the safety sensor is running or first to use the appliance you should open the safety sensor at first.
- Touch the timer sensor if you want to use the time for cooking.
- Place your fingertip on - or + to set the cooking time..

Make sure you touch the sensor corresponding to the ring you wish to use. Select the desired power setting by leaving your finger on the control.

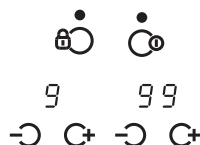

IMPORTANT

- If all the rings are turned off, the hob will switch off in a few seconds, and **H** will light up to indicate which rings are still hot.
- You can activate the safety sensor whenever you wish by holding your fingertip on the sensor for three seconds.
- If any objects are left on the sensors, the hob will beep several times and then switch off.
- The hob will automatically switch off after two hours, due the any ring is work but have any modify or new cooking setting to the induction in the two hours.

TIMER FUNCTION

For the timer function it just can control only one ring. If time function is running the point that local on the cooking zone power display will be high light. If you want to cancel the timer you can use the lessen sensor to set the time to 0.

PAN

Use the magnet supplied in the bag to test whether a pan is suitable. If the magnet sticks to the bottom of the pan, it can be used for induction cooking. The induction ring display itself will also show you whether the pan is suitable, If the power indicator is flashing and show E0. the pan is not suitable and the ring will not heat up.

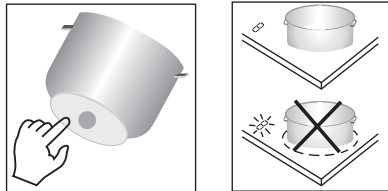

IMPORTANT

If the pan has a very small base, the ring will also flash and it will not heat up, even if the metal is suitable. We recommend not to use pans with a smaller base than these:
280 ring---->160 diameter 210 ring ---->180 diameter
180 ring---->160diameter 150 ring ---->120 diameter

Glass, ceramic, earthen-ware, aluminium, copper and non-magnetic stainless steel pans are generally unsuitable. However, enamelled stainless steel pans with a special base suitable for induction cooking may be used (make sure the pan is lable as suitable for induction cooking).

Induction heat is generated very rapidly, in the base of the pan itself. You should therefore never heat an empty pan.

Different types of pan are suitable for induction cooking, but those with a thick base are the best. A more efficient use will be made of the heat and it will be better



distributed.

Avoid scraping the glass of the hob when you move the pans. Lift them up to move them.

Do not leave any cooking utensils on the hob when it is switched on. It could detect them as pans and heat them up.

Cutlery will not normally be detected as such, but a larger utensil might be.

IMPORTANT

Keep an eye on pressure cookers when using the higher induction settings. They heat up very quickly.

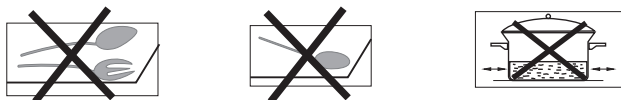

WHAT SHOULD I DO IF

YOU NOTICE THAT	POSSIBLE CAUSES	WHAT SHOULD YOU DO
The induction hob is not working. The pilot lights on the keypad are all off	There is no electrical supply to the appliance. The supply or connection is defective.	Check the state of the electrical installation. Check the fuses and differential switches.
the fan keep running for a few minutes after the unit has been switched off	the electronics is cooling down	this is a normal occurrence
your hob makes faint clicking noise when in operation	this noise occurs when the power is being shared between two induction coils	this is a normal occurrence
your utensil creates noise during cooking	your utensil creates noise from vibrations caused by induced current	under high power this phenomenon is normal with some type of pots and pans. There is no danger for the hob
The power display on the keypad continue to flash and show E0 when the appliance is functioning.	The pan being use is not suitable for induction cooking.	Use a compatible pan. pans can be tested with the magnet.
The power display on the keypad continue to flash and show E3 or E4 or E5 and shut off automatism	The appliance is work in the danger state	Shut off the appliance and open the unit again after some time.
The hob continues to ventilate for several minutes after switching off.	The electronic circuits are cooling down.	This is normal.
The hob is not working and a different message appears.	The electronic circuit is not working correctly.	Contact the after-sales service.

Technical Information

Technical details

Class 1 hob.

Dimensions and characteristics

Model	IR321.1
Hob dimensions	
Height (mm)	69
Length (mm)	510
Width (mm)	290
Dimensions of the placement in the unit	
Length (mm)(L)	490
Width (mm) (W)	270
Depth (mm)	70
Configuration	
Induction hotplate 1200W	1
Induction hotplate 1800W	1
Electrics	
Nominal Power (W) for 230 V	3000
Supply voltage (V)	230V
Frequency (Hz)	50/60

*Induction power with the power function enabled